



Standard Test Methods for Rubber—Identification by Infrared Spectrophotometry¹

This standard is issued under the fixed designation D3677; the number immediately following the designation indicates the year of original adoption or, in the case of revision, the year of last revision. A number in parentheses indicates the year of last reapproval. A superscript epsilon (ϵ) indicates an editorial change since the last revision or reapproval.

This standard has been approved for use by agencies of the U.S. Department of Defense.

1. Scope

1.1 These test methods cover rubber identification and are based on infrared examination of pyrolysis products (pyrolyzates) and films.

1.2 These test methods are applicable to rubbers in the raw state and, when compounded, both in the cured and uncured state.

1.3 Since it is customary in infrared spectrophotometry to use wavenumbers (cm^{-1}) rather than Hertz (Hz), the unit for frequency in the SI system, the former is employed throughout this test method.

1.4 This test method assumes that specimens and infrared spectra are prepared and analyzed by experienced personnel and that the equipment is operated according to the manufacturer's direction for optimum performance. No details for operation of infrared spectrophotometers are included in this test method.

1.5 *This standard does not purport to address all of the safety concerns, if any, associated with its use. It is the responsibility of the user of this standard to establish appropriate safety and health practices and determine the applicability of regulatory limitations prior to use.* Specific precautionary statements are given in Section 17.

2. Referenced Documents

2.1 ASTM Standards:²

D297 Test Methods for Rubber Products—Chemical Analysis

D1418 Practice for Rubber and Rubber Latices—Nomenclature

D3452 Practice for Rubber—Identification by Pyrolysis-Gas Chromatography

¹ These test methods are under the jurisdiction of ASTM Committee D11 on Rubber and are the direct responsibility of Subcommittee D11.11 on Chemical Analysis.

Current edition approved June 1, 2015. Published September 2015. Originally approved in 1978. Last previous edition approved in 2010 as D3677 – 10 ϵ^1 . DOI: 10.1520/D3677-10R15.

² For referenced ASTM standards, visit the ASTM website, www.astm.org, or contact ASTM Customer Service at service@astm.org. For *Annual Book of ASTM Standards* volume information, refer to the standard's Document Summary page on the ASTM website.

E168 Practices for General Techniques of Infrared Quantitative Analysis (Withdrawn 2015)³

3. Significance and Use

3.1 For research, development, and quality control purposes, it is advantageous to determine the composition of rubbers in cured, compounded products.

3.2 This test method provides such composition analysis utilizing an infrared technique.

4. Reagents

4.1 *Purity of Reagents*—Reagent grade chemicals shall be used in all tests. Unless otherwise indicated, it is intended that all reagents shall conform to the specifications of the Committee on Analytical Reagents of the American Chemical Society, where such specifications are available.⁴ Other grades may be used, provided it is first ascertained that the reagent is of sufficiently high purity to permit its use without lessening the accuracy of the determination.

4.2 *Acetone.*

4.3 *Alcohol*, ethanol, denatured.

4.4 *2-Butanone.*

4.5 *Chloroform.*

4.6 *Congo Red Paper.*

4.7 *Diatomaceous Filter Aid*—Some grades are quite unsatisfactory in that they will not sufficiently absorb carbon black.

4.8 *1,2-Dichlorobenzene*—A check on suitability may be made by evaporating 50 cm^3 to dryness and making an infrared spectrum of the residue. Any substantial absorbance at positions near those wavenumbers that will be used for rubber analysis, indicates that the 1,2-dichlorobenzene is unsuitable for use.

³ The last approved version of this historical standard is referenced on www.astm.org.

⁴ *Reagent Chemicals, American Chemical Society Specifications*, American Chemical Society, Washington, DC. For suggestions on the testing of reagents not listed by the American Chemical Society, see *Analar Standards for Laboratory Chemicals*, BDH Ltd., Poole, Dorset, U.K., and the *United States Pharmacopeia and National Formulary*, U.S. Pharmaceutical Convention, Inc. (USPC), Rockville, MD.

4.9 *Dry Compressed Air and Nitrogen*, in cylinders, or provided as a laboratory service.

4.11 *Toluene*.

4.10 *Sodium Sulfate*, anhydrous.

TEST METHOD A QUALITATIVE ANALYSIS

5. Scope

5.1 This test method, based on infrared examination of pyrolysis products (pyrolyzates) and films, will identify the rubbers in 6.1 occurring alone or in binary blends in the range from 80 % major component to 20 % minor component. Exceptions to this will be found in 6.2.

5.2 This test method is applicable to rubbers in the raw state and, when compounded, both in the cured and uncured state.

5.3 This test method implies that sample preparation and infrared spectrum are prepared and analyzed by experienced personnel and that the equipment used for the production of the spectra is operated according to the manufacturer's directions for optimum performance. No details for operation of infrared spectrophotometers are included in these test methods.

6. Field of Application

6.1 Infrared examinations of pyrolyzates and films will identify mixtures of two of the following types of rubbers in the range from 80 % major component to 20 % minor component. (See the exceptions in 6.2.)

6.1.1 *Isoprene Rubbers* (see 6.2.1):

6.1.1.1 Natural rubber, synthetic polyisoprene, gutta percha, and balata are included.

6.1.1.2 Examination of the pyrolyzate will not distinguish between the different forms of polyisoprene.

6.1.1.3 Examination of a film will distinguish natural and synthetic polyisoprene from balata and gutta percha.

6.1.2 *Styrene-Butadiene Rubbers with Styrene Content of Approximately 23.5 % Styrene* (see 6.2.2):

6.1.2.1 For the purpose of this standard, all copolymers of styrene and butadiene and their oil-extended forms are included.

6.1.2.2 Examination of the pyrolyzate will not distinguish between emulsion and solution polymerized rubbers.

6.1.2.3 Examination of films may give some information about the monomer ratio and the polymerization system.

6.1.3 *Acrylonitrile-Butadiene Rubber with Acrylonitrile Content of Approximately 33 %*:

6.1.3.1 Examination of the pyrolyzate will not measure the ratio of acrylonitrile to butadiene.

6.1.3.2 Examination of a film may give some information about the acrylonitrile content.

6.1.4 *Chloroprene Rubber*—This test method will not distinguish between the different types of chloroprene rubbers.

6.1.5 *Butyl Rubber*— This test method will not distinguish between butyl rubber and its halogenated forms.

6.1.6 *Polybutadiene Rubber (High cis)*:

6.1.6.1 Examination of the pyrolyzate will not distinguish between polybutadiene rubbers having different isomer ratios.

6.1.6.2 Examination of a film may give some information about the monomer ratio.

6.1.7 *Ethylene-Propylene Rubbers* (see 6.2.3)—This test method will not distinguish between rubbers having different ratios of ethylene to propylene nor between copolymers and terpolymers.

6.2 Exceptions to the rubbers listed in 6.1 are:

6.2.1 A blend of natural or synthetic isoprene (20 %) and chloroprene (80 %), or both, may present difficulties, and identification of the minor component may be achieved only when its content is equal to or more than 30 % in the blend.

6.2.2 A blend of butadiene-styrene rubber (80 %) and high *cis* polybutadiene rubber (20 %) may present difficulties, and identification of the minor component may only be achieved when it is equal to or more than 30 % in the blend.

6.2.3 Ethylene-propylene rubber in blends with other rubbers presents difficulties when its content is in the range from 20 to 40 %.

6.3 In difficult cases, examination of the gaseous products of pyrolysis by gas chromatography (Practice D3452) may give further information.

7. Summary of Test Method

7.1 *Identification from Pyrolyzates*:

7.1.1 A small quantity of extracted and dried rubber is pyrolyzed in a stream of nitrogen in a test tube held in a small electric, thermo-regulated furnace at 450 to 500°C, or alternatively, rapidly pyrolyzed in a small test tube held in the hot zone of a gas flame.

7.1.2 A test for chlorine is conducted during pyrolysis.

7.1.3 A few drops of the pyrolyzate are transferred to a salt plate and an infrared spectrum recorded over the 4000 to 666 cm^{-1} region.

7.1.4 The rubber is identified by comparison to standard reference spectra and by reference to a table of diagnostic absorptions (significant absorption frequencies).

7.1.5 Each laboratory employing this standard must prepare spectra of all rubbers they might be expected to identify. These spectra must be prepared in the same manner and using the same equipment as will be used for unknown samples.

7.2 *Identification from Films*:

7.2.1 A small quantity of extracted and dried rubber is dissolved in 1,2-dichlorobenzene, filtered, and a film cast on a salt plate. This film is used as in 7.1.4.

7.2.2 A small quantity of extracted and dried rubber is subjected to mild thermal degradation at $200 \pm 5^\circ\text{C}$ for a short time. The degraded sample is dissolved in trichloroethylene then chloroform, and a film cast on a salt plate. This film is used as in 7.1.4.

8. Apparatus

8.1 Extraction Apparatus:

8.1.1 The extraction apparatus used shall be of the general type and dimensions shown in Fig. 1.

8.2 *Test Tubes*, small, and other necessary glassware sufficient to carry out the test as written.

8.3 *Pyrolysis Apparatus* (Fig. 2)—The pyrolysis apparatus consists of a glass tube (*P*) having inward projections to prevent the sample from falling to the bottom of the tube and a lateral condenser tube. The tube (*P*) has a ground-glass standard taper (*S*) which carries a small glass adductor tube. A collecting tube (*T*) is placed under the condenser tube. An electric, thermoregulated furnace (*F*) accommodates an aluminum block (*H*) with holes for one or more tubes (*P*).

8.4 Capillary Pipets.

8.5 *Oven*, capable of maintaining a temperature of $200 \pm 5^\circ\text{C}$ for use in 10.2.

8.6 Water Bath, for use in 10.2.

8.7 *Salt Plates*, polished (sodium chloride or potassium bromide), 4 by 25 mm, to serve as windows for the spectrophotometer.

8.8 *Infrared Spectrophotometer, High-Resolution Scanning or Fourier Transform*, capable of recording a spectrum over the 4000 to 667 cm^{-1} region. (High resolution⁵ requires that the

⁵ High resolution is defined in "Specification for Evaluation of Research Quality Analysis of Infrared Spectra," *Analytical Chemistry*, ANCHA, Vol 47, No. 11, p. 94A.

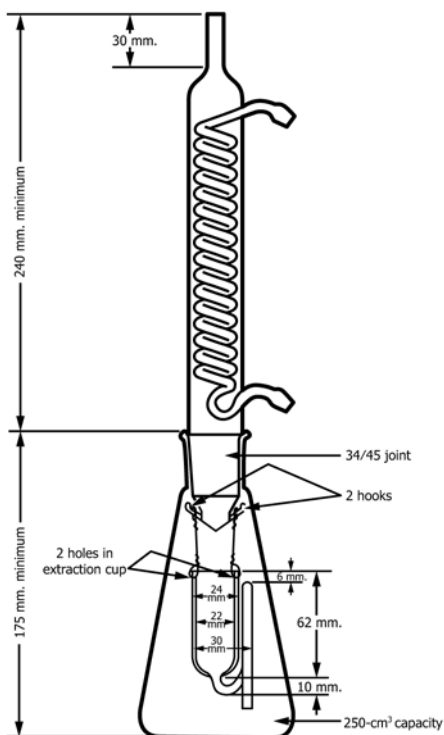
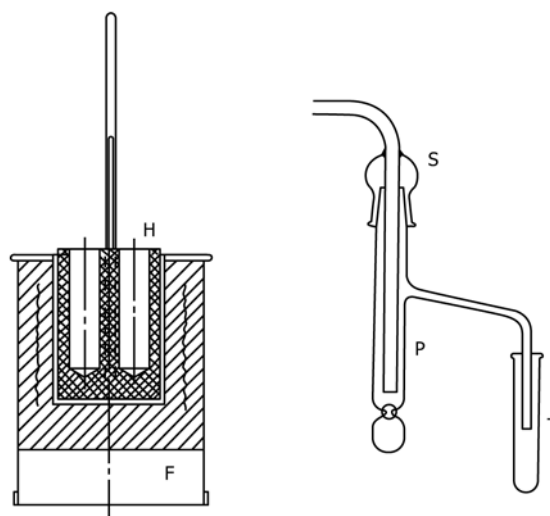

FIG. 1 Extraction Apparatus with Glass Condenser and Ground Glass Joint



F electric, thermoregulated furnace
H aluminum block, bored to hold tubes
P glass tube for sample container
S ground-glass taper
T collecting tube

FIG. 2 Temperature Controlled Pyrolysis Apparatus

spectral slit width should not exceed 2 cm^{-1} over 80 % of the wavenumber range and at no place should it exceed 5 cm^{-1} .) Any spectrophotometer complying with these requirements may be used. The equipment shall be operated by an experienced analyst according to the manufacturer's directions for optimum performance.

9. Preparation of Test Portion

9.1 *Temperature Controlled Pyrolysis in a Stream of Nitrogen* (Fig. 2; Preferred Method):

9.1.1 Prepare the test portion by milling into a thin sheet on a laboratory mill or cutting into cubes about 2 mm wide and wrap approximately 0.5 g in filter paper or nylon cloth. Extract the wrapped test portion in an extraction cup in accordance with Section 19 of Test Methods D297, for a minimum of 4 h with methanol, ethanol, or 2-propanol. A vulcanizate may be extracted with acetone or 2-butanone, in addition to the above alcohols. Alternatively, the rapid reflux procedure may be used for 1 h in accordance with Section 26 of Test Methods D297.

9.1.2 Remove the extracted rubber from the apparatus and dry at 100°C until free of solvent. One to two hours is usually required.

9.1.3 Introduce a small amount of anhydrous sodium sulfate into the collecting tube (*T*) to absorb water produced during pyrolysis.

9.1.4 Place a strip of moistened Congo red paper across the mouth of the tube, as a test for chlorine (a change from red to blue).

9.1.5 If alternative chlorine determining methods are employed, this procedure must be suitably modified.

9.1.6 Bring the electrical furnace (*F*) to 450 to 500°C and hold at this temperature. This range is recommended to obtain